

B1

**Tolva para semillas y fertilizantes.
Auger wagon for seeds and fertilizers.**



B1 20000L

Cestari

B1 20.000 l Es el nombre de la tolva.
Para optimizar tu siembra, que también es cestari.
Acoplado preparado para carga y descarga
de semillas y fertilizantes.

Auger wagon for seeds and fertilizers this wagon
has been developed for loading and unloading seeds
and fertilizers, specially designed to load large sized
seeders: air drill and conventional system.

B1200000L

**POSICIÓN DE TRANSPORTE
TRANSPORT POSITION**



CARACTERÍSTICAS TÉCNICAS

Apta para carga/ descarga y transporte de semillas y fertilizantes.

Dos ejes

Capacidad: 20.000 litros

Diámetro de tubo sinfín: 220 mm

Rodado de alta flotación (600/50 - 22.5) o duales

Divisorio interior para carga de semillas y fertilizantes.

Sist. de suspensión con ballestas (resortes) y tensores (mejor transitabilidad).

Tara 4500 kg. (con llantas) y neumáticos

ACCESORIOS ADICIONALES

Enganche trasero

Tanque PVC para agua (60 litros). Tanque para líquido curador de semillas.

Lona enrollable por el operador, desde el piso.

Bauleras en sus frentes (trasero y delantero)

POSICIÓN DE DESCARGA UNLOADING POSITION



TECHNICAL CHARACTERISTICS

Developed for loading/unloading and transportation of seeds and fertilizers

Dual axle

Capacity: 20.000 liters

Diameter of the Auger tube: 220 mm

High flotation tyres (600/50 - 22.5) or duals

Inner compartment for seeds and fertilizers loading

Suspension system with leaf springs and tensors for a better trafficability.

Tare 4500 kg. (with rims) and tyres.

ADDITIONAL ACCESORIES

Rear hitch

PVC tank for water. Tank for inoculant.

Roll top canvas system

Plastic storage trunk box (front and rear)

**POSICIÓN DE AUTOCARGA
SELF-LOADING POSITION**

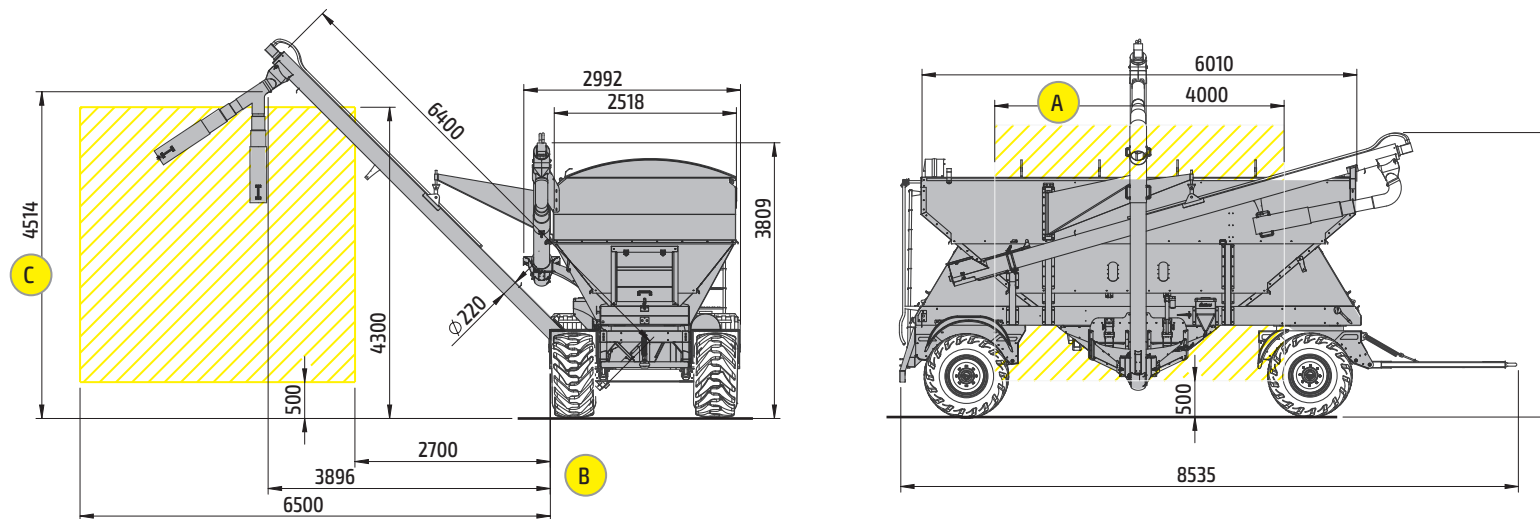

A Ancho de trabajo, sin necesidad de desplazamiento: 4.000 mm
Working width, without displacement: 4,000 mm

B Distanciamiento máximo de trabajo respecto a la tolva: de 2.700 a 6.500 mm
Maximum working distance with respect to the cart: from 2,700 to 6,500 mm

C Altura máxima descarga: 4.514 mm
Maximum unloading height: 4,514 mm



1



2



3



4



5

6



7



8



9



10

EQUIPAMIENTO EQUIPMENT

1. Estructura completamente abulonada.
2. Divisorio interior para carga de semillas y fertilizantes.
2. Pasarela interna
3. Diámetro de tubo sinfín: 220 mm
4. Sistema de suspensión con ballestas y tensores.
5. Tanque para líquido curador de semillas.
6. Tanque PVC para agua (60 litros).
7. Lona enrollable por el operador, desde el piso.
8. Bauleras en sus frentes (trasero y delantero).
9. Eganche trasero
10. Conexión trasera - hidráulica y eléctrica.

OPCIONALES

Balanza incorporada en las puntas de eje.
Apertura de boquilla de descarga con mando a distancia.
Balanza incorporada en las puntas de eje
(sin modificar la altura).

1. Completely bolted structure.
2. Inner compartment for seeds and fertilizers loading.
2. Internal footbridge
3. Diameter of the Auger tube: 220 mm.
4. Suspension system with leaf springs and tensors.
5. Tank for inoculant.
6. PVC tank for water (60 liters).
7. Roll top canvas system.
8. Plastic storage trunk box (front and rear).
9. Rear hitch.
10. Rear connection – hydraulic and electrical

OPTIONAL

Scales in spindle.
Unloading nozzle with remote control opening.
Scales in spindle (without any height change).

www.imcestari.com



CestariTolvas

INDUSTRIAS METALÚRGICAS CESTARI S.R.L.

+54 2473 430490 / informes@imcestari.com / Colón Buenos Aires, Argentina

S6



S6 24000L 2R



S6 31000L 2R



S6 37000L 2R

Cestari

CESTARIS62R

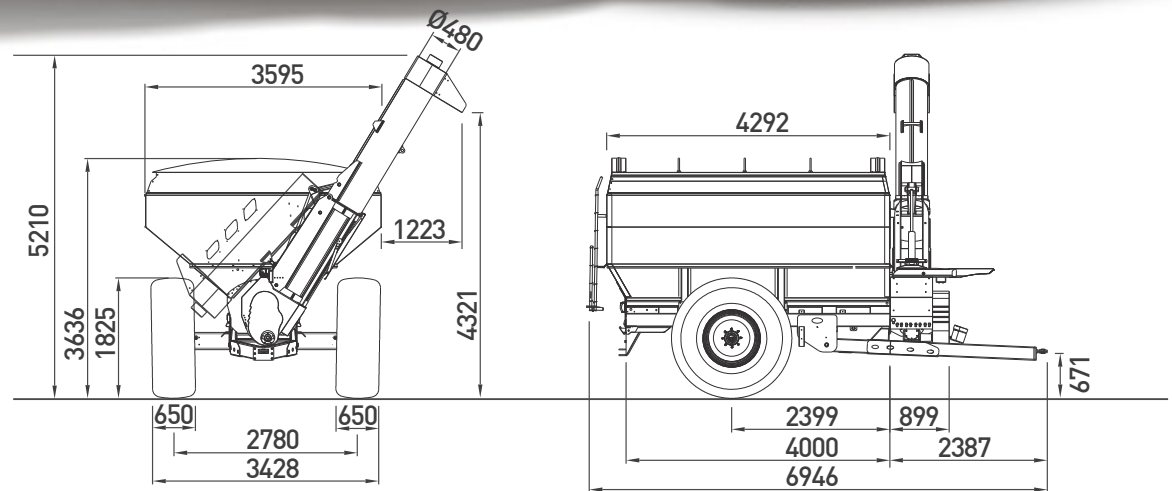

S6 24000L 2R

Capacidad (Lts.) sin rebase superior.	Capacity -Not exceed the upper edge-	24.000 L	Llantas / Rims
Tubo de descarga (∅)	Unloading tube (∅)	480 mm	DW 20x30 – 10 aguj
Tiempo de descarga (*1)	Unloading time (*1)	2.50 min	DW 21x32 – 10 aguj
Peso tara (*2)	Weight tare (*2)	3.200 Kg	DW 27x32 – 10 aguj
Potencia de tractor requerida	Tractor power required	125 HP	DW 25x26 – 10 aguj
Sinfín de piso (∅)	Floor auger (∅)	380 mm	Neumáticos / Tires
Sinfín de tubo (∅)	Tube auger (∅)	454 mm	23.1-30 R1 y R3
			24.5-32 R1 y R3
			30.5L-32 R1 y R3
			28L-26 R3

(*1) Cereal seco a 540 rpm ; (*2) Con llantas, Sin neumáticos. / (*1) Dry cereal at 540 rpm; (*2) With rims, without tires.

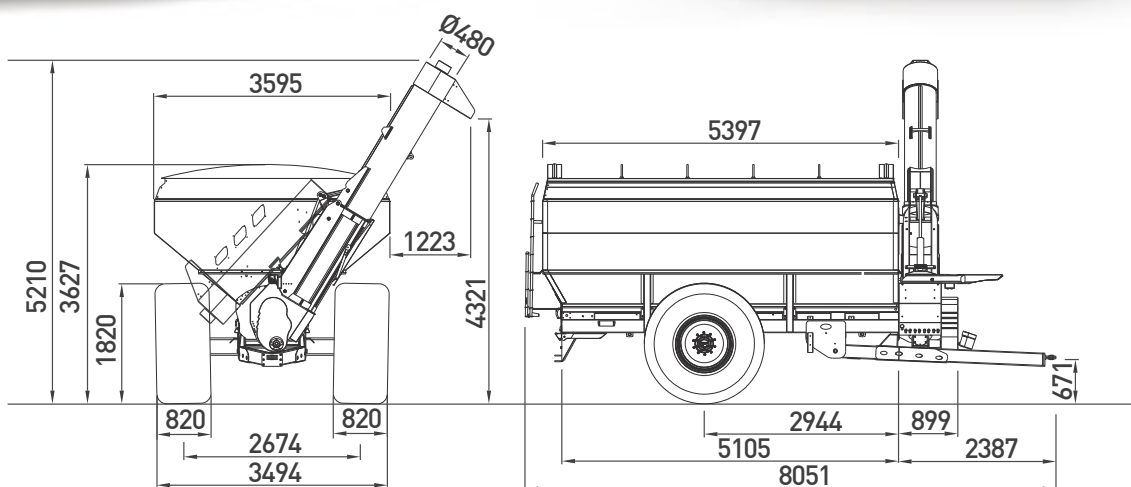

S6 31000L 2R

Capacidad sin rebase superior.	Capacity -Not exceed the upper edge-	31.000 L	Llantas / Rims
Tubo de descarga (\varnothing)	Unloading tube (\varnothing)	480 mm	DW 27x32 – 10 aguj
Tiempo de descarga (*1)	Unloading time (*1)	3.35 min	DW 30Bx32 – 10 aguj
Peso tara (*2)	Weight tare (*2)	4.100 Kg	Neumáticos / Tires
Potencia de tractor requerida	Tractor power required	140 HP	30.5L 32 R1 y R3
Sinfín de piso (\varnothing)	Floor auger (\varnothing)	380 mm	800/65 R32
Sinfín de tubo (\varnothing)	Tube auger (\varnothing)	454 mm	900/60 R32

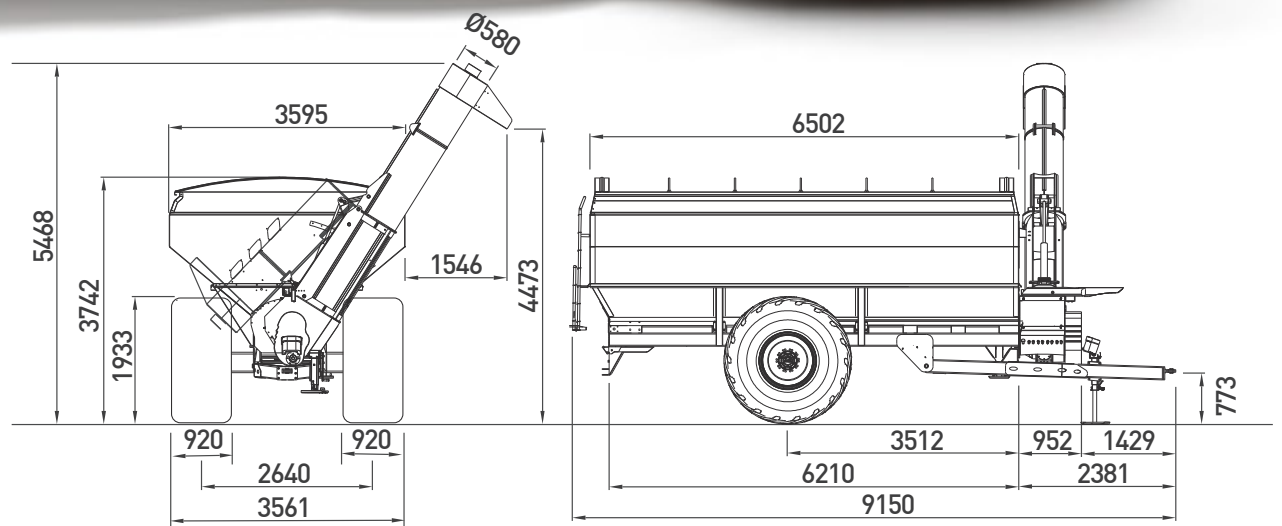

S6 37000L 2R

Capacidad sin rebase superior.	Capacity -Not exceed the upper edge-	37.000 L
Tubo de descarga (Ø)	Unloading tube (Ø)	580 mm
Tiempo de descarga (*1)	Unloading time (*1)	3.25 min
Peso tara (*2)	Weight tare (*2)	5.500 Kg
Potencia de tractor requerida	Tractor power required	180 HP
Sinfín de piso (Ø)	Floor auger (Ø)	470 mm
Sinfín de tubo (Ø)	Tube auger (Ø)	554 mm

Llantas / Rims
 DW 27x32 – 10 aguj
 DW 30Bx32 – 10 aguj
 DW 36Bx32 – 10 aguj

Neumáticos / Tires
 30.5L R32
 800/65 R32
 900/60 R32
 1050/50 R32



EQUIPAMIENTO EQUIPMENT

1. Tolva totalmente abulonada.
2. Cobertor de unión de tubo de descarga.
3. Sombrero doble de piso.
4. Guía pasamangueras giratorio.
Lubricación externa centralizada.
5. sistema de lanza móvil con amortiguadores.
6. Sistema de limpieza con mayor área de apertura.
7. Tapa desmontable trasera de sinfines de piso para limpieza.
8. Visor de cereal. (delantero y triple: mejor visualización).
9. Reflector led en tubo de descarga.

Cajón de herramientas. / Eganche delantero con rótula. / Escaleras traseras rebatibles e interior. / Gato de elevación. / Indicador de apertura de compuertas de piso. / Manija de lanza de tiro a ambos lados. / Organizador de mangueras. / Portafaros rebatibles. / Sistema de descarga de cereal por gravedad más ágil. / Sistema de lona enrollable. / Sistema hidráulico triple: movimiento de tubo, compuertas de piso y fondo deslizante (limpieza y descarga por gravedad). Tubo de descarga con mayor plegado / Cilindro hidráulico de tubo con sistema de reducción de velocidad. / Tubo inferior desmontable.

1. Completely bolted grain cart.
2. Joining cover of Unloading tube.
3. Double Floor cover.
4. Rotary guide for hoses.
Centralized lubrication system.
5. Damping towbar system.
6. Cleaning system with a greater opening area.
7. Removable rear cover of floor augers for a better cleaning.
8. Cereal viewer (front and triple for a better visualization)
9. Unloading tube led spotlight.

Plastic toolbox. / Front hitch with kneecap. / Standard Ladders: rear hinged and internal. / Lifting Jack. / Floor hatches opening indicator. / Centralised lubrication system. / Drawbar handgrip on both sides. / Hose organizer. / Hinged rear lights. / Smoother gravity unloading system. / Roll top canvas system. / Hydraulic System (triple): tube, floor hatches and bottom sliding floor movement. / Unloading tube with better folding. / Tube hydraulic cylinder with speed reduction system / Removable lower unloading tube (extension casing).

www.imcestari.com



CestariTolvas

INDUSTRIAS METALÚRGICAS CESTARI S.R.L.

+54 2473 430490 / informes@imcestari.com / Colón Buenos Aires, Argentina

S6



S6 31000L 4R



S6 37000L 4R



S6 43000L 4R

Cestari

CESTARIS64R

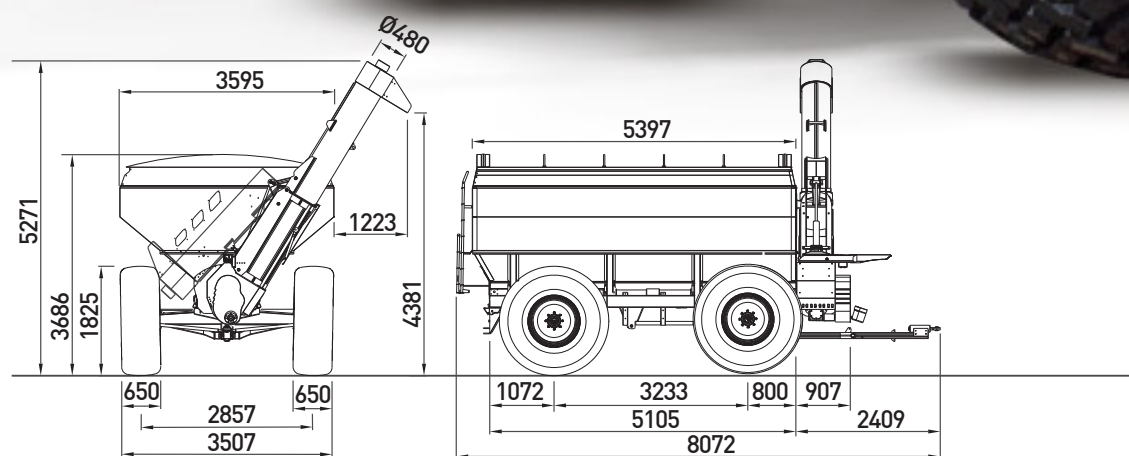

S6 31000L 4R

Capacidad sin rebase superior	Capacity -Not exceed the upper edge-	31.000 L
Tubo de descarga (∅)	Unloading tube (∅)	480 mm
Tiempo de descarga (*1)	Unloading time (*1)	3.35 min
Peso tara (*2)	Weight tare (*2)	5.000 Kg
Potencia de tractor requerida	Tractor power required	150 HP
Sinfín de piso (∅)	Floor auger (∅)	380 mm
Sinfín de tubo (∅)	Tube auger (∅)	454 mm

Llantas / Rims
 DW 20x30 – 10 aguj
 DW 21x32 – 10 aguj

Neumáticos / Tires
 23.1-30 R3
 24.5-32 R3

(*1) Cereal seco a 540 rpm ; (*2) Con llantas, Sin neumáticos. / (*1) Dry cereal at 540 rpm; (*2) With rims, without tires.

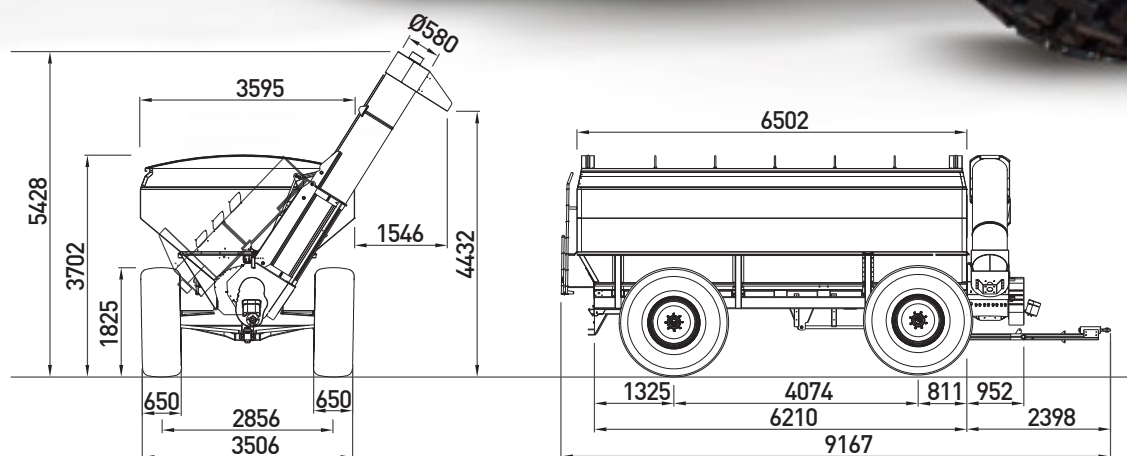

S6 37000L 4R

Capacidad sin rebase superior	Capacity -Not exceed the upper edge-	37.000 L
Tubo de descarga (∅)	Unloading tube (∅)	580 mm
Tiempo de descarga (*1)	Unloading time (*1)	3.2 min
Peso tara (Kg) (*2)	Weight tare (*2)	6.300 Kg
Potencia de tractor requerida	Tractor power required	200 HP
Sinfín de piso (∅)	Floor auger (∅)	470 mm
Sinfín de tubo (∅)	Tube auger (∅)	554 mm

Llantas / Rims
 DW 27x32 – 10 aguj
 DW 30Bx32 – 10 aguj

Neumáticos / Tires
 30.5L 32 R1 y R3
 800/65 R32

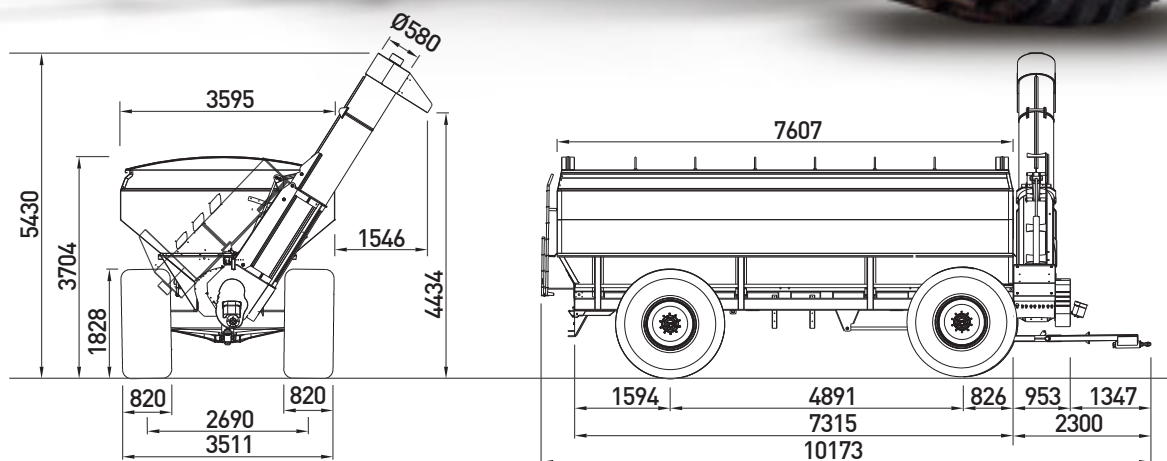

S6 43000L 4R

Capacidad sin rebase superior	Capacity -Not exceed the upper edge-	43.000 L
Tubo de descarga (∅)	Unloading tube (∅)	580 mm
Tiempo de descarga (*1)	Unloading time (*1)	4.0 min
Peso tara (*2)	Weight tare (*2)	7.050 Kg
Potencia de tractor requerida	Tractor power required	225 HP
Sinfín de piso (∅)	Floor auger (∅)	470 mm
Sinfín de tubo (∅)	Tube auger (∅)	554 mm

Llantas / Rims
DW 27/32 – 10 aguj

Neumáticos / Tires
30.5L R32 R3
800/65 R32

**1****2****3****4****5****6****7****8****9**

EQUIPAMIENTO EQUIPMENT

1. Tolva totalmente abulonada.
2. Cobertor de unión de tubo de descarga.
3. Sombrero doble de piso.
4. Guía pasamangueras giratorio.
5. Reflector led en tubo de descarga.
6. Sistema de limpieza con mayor área de apertura.
7. Tapa desmontable trasera de sinfines de piso para limpieza.
8. Visor de cereal. (delantero y triple: mejor visualización).
9. Lubricación externa centralizada.

Cajón de herramientas. / Enganche delantero con rótula. / Escaleras traseras rebatibles e interior. / Indicador de apertura de compuertas de piso. / Manija de lanza de tiro a ambos lados. / Organizador de mangueras. / Portafaros rebatibles. / Sistema de descarga de cereal por gravedad más ágil. / Sistema de lona enrollable. / Sistema hidráulico triple: movimiento de tubo, compuertas de piso y fondo deslizante (limpieza y descarga por gravedad). / Tubo de descarga con mayor plegado / Cilindro hidráulico de tubo con sistema de reducción de velocidad. / Tubo inferior desmontable.

1. Completely bolted grain cart.
2. Joining cover of Unloading tube.
3. Double Floor cover.
4. Rotary guide for hoses.
5. Unloading tube led spotlight.
6. Cleaning system with a greater opening area.
7. Removable rear cover of floor augers for a better cleaning.
8. Cereal viewer (front and triple for a better visualization)
9. Centralized lubrication system.

Plastic toolbox. / Front hitch with kneecap. / Standard Ladders: rear hinged and internal. / Floor hatches opening indicator. / Drawbar handgrip on both sides. / Hose organizer. / Hinged rear lights. / Smoother gravity unloading system. / Roll top canvas system. / Hydraulic System (triple): tube, floor hatches and bottom sliding floor movement. / Unloading tube with better folding. / Tube hydraulic cylinder with speed reduction system / Removable lower unloading tube (extension casing).

www.imcestari.com



CestariTolvas

INDUSTRIAS METALÚRGICAS CESTARI S.R.L.

+54 2473 430490 / informes@imcestari.com / Colón Buenos Aires, Argentina

S6



S6 43000L TRACK

Cestari

S643000TRACK

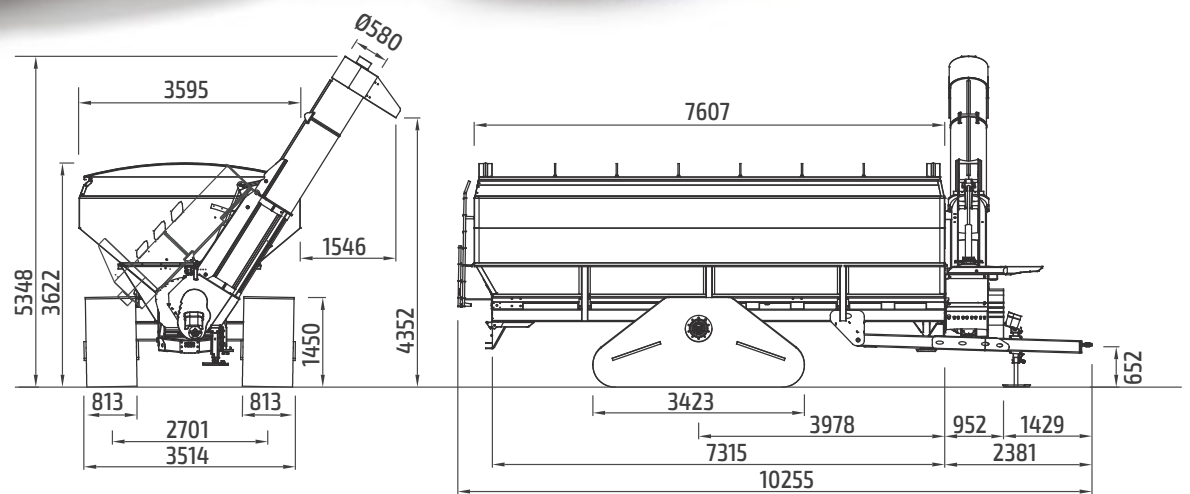

S6 43000LTRACK

Capacidad sin rebase superior.	Capacity -Not exceed the upper edge-	43.000 L
Tubo de descarga (∅)	Unloading tube (∅)	580 mm
Tiempo de descarga (*1)	Unloading time (*1)	4.00 min
Peso tara sin orugas	Weight tare without track system	6.300 Kg
Peso tara con orugas (Modelo ST)	Weight tare with track system (ST Model)	9.920 Kg
Potencia de tractor requerida	Tractor power required	200 HP
Sinfín de piso (∅)	Floor auger (∅)	470 mm
Sinfín de tubo (∅)	Tube auger (∅)	554 mm

Tren de orugas /
Track system
(ST Model)
Largo / Length:
3300 mm.
Ancho / Width:
813 mm.

(*1) Cereal seco a 540 rpm. / (*1) Dry cereal at 540 rpm.

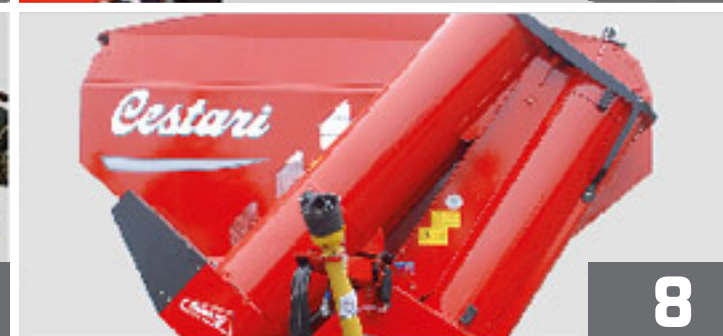
**1****2****3****4****5****6****7****8****9**

EQUIPAMIENTO EQUIPMENT

1. Tolva totalmente abulonada.
2. Cobertor de unión de tubo de descarga.
3. Sombrero doble de piso.
4. Guía pasamangueras giratorio.
Lubricación externa centralizada.
5. Sistema de lanza móvil con amortiguadores.
6. Sistema de limpieza con mayor área de apertura.
7. Tapa desmontable trasera de sinfines de piso para limpieza.
8. Visor de cereal. (delantero y triple: mejor visualización).
9. Reflector led en tubo de descarga.

Cajón de herramientas. / Enganche delantero con rótula. / Escaleras traseras rebatibles e interior. / Gato de elevación. / Indicador de apertura de puertas de piso. / Manija de lanza de tiro a ambos lados. / Organizador de mangueras. / Portafaros rebatibles. / Sistema de descarga de cereal por gravedad más ágil. / Sistema de lona enrollable. / Sistema hidráulico triple: movimiento de tubo, compuertas de piso y fondo deslizante (limpieza y descarga por gravedad). Tubo de descarga con mayor plegado / Cilindro hidráulico de tubo con sistema de reducción de velocidad. / Tubo inferior desmontable.

1. Completely bolted grain cart.
2. Joining cover of Unloading tube.
3. Double Floor cover.
4. Rotary guide for hoses.
Centralized lubrication.
5. Damping towbar system.
6. Cleaning system with a greater opening area.
7. Removable rear cover of floor augers for a better cleaning.
8. Cereal viewer (front and triple for a better visualization)
9. Unloading tube led spotlight.

Plastic toolbox. / Front hitch with kneecap. / Standard Ladders: rear hinged and internal. / Lifting Jack / Floor hatches opening indicator. / Centralised lubrication system. / Drawbar handgrip on both sides. / Hose organizer. / Hinged rear lights. / Smoother gravity unloading system. / Roll top canvas system. / Hydraulic System (triple): tube, floor hatches and bottom sliding floor movement. / Unloading tube with better folding. / Tube hydraulic cylinder with speed reduction system / Removable lower unloading tube (extension casing).

www.imcestari.com



CestariTolvas

INDUSTRIAS METALÚRGICAS CESTARI S.R.L.

+54 2473 430490 / informes@imcestari.com / Colón Buenos Aires, Argentina



INDUSTRIAS METALURGICAS CESTARI S.R.L.

ST SERIES

- [*1] CON LLANTAS SIN NEUMÁTICOS
WITH RIMS, WITHOUT TIRES.
- [*2] SIN REBASE SUPERIOR
NOT EXCEED THE UPPER EDGE.
- [*3] CEREAL SECO A 540 R.P.M.
DRY CEREAL AT 540 RPM.



14.800 L

ESPECIFICACIONES TECNICAS TECHNICAL SPECIFICATIONS

Peso Tara	Weight Tare:	2.400 kg. [*1]
Capacidad	Capacity:	14.800 Lts. [*2]
Carga máxima	Maximum load:	13.000 Kg.
Ø tubo	Ø Tube:	420 mm.
Ø sinfín de piso	Ø Floor auger:	336 mm.
Ø sinfín de tubo	Ø Tube auger:	396 mm.
Tiempo de descarga	Unloading time:	2 min. [*3]

EQUIPAMIENTO

Llantas DW 20x30
Neumáticos: 23.1-30 R1 y R3

EQUIPMENT

Rims: DW 20x30
Tires: 23.1-30 R1 and R3

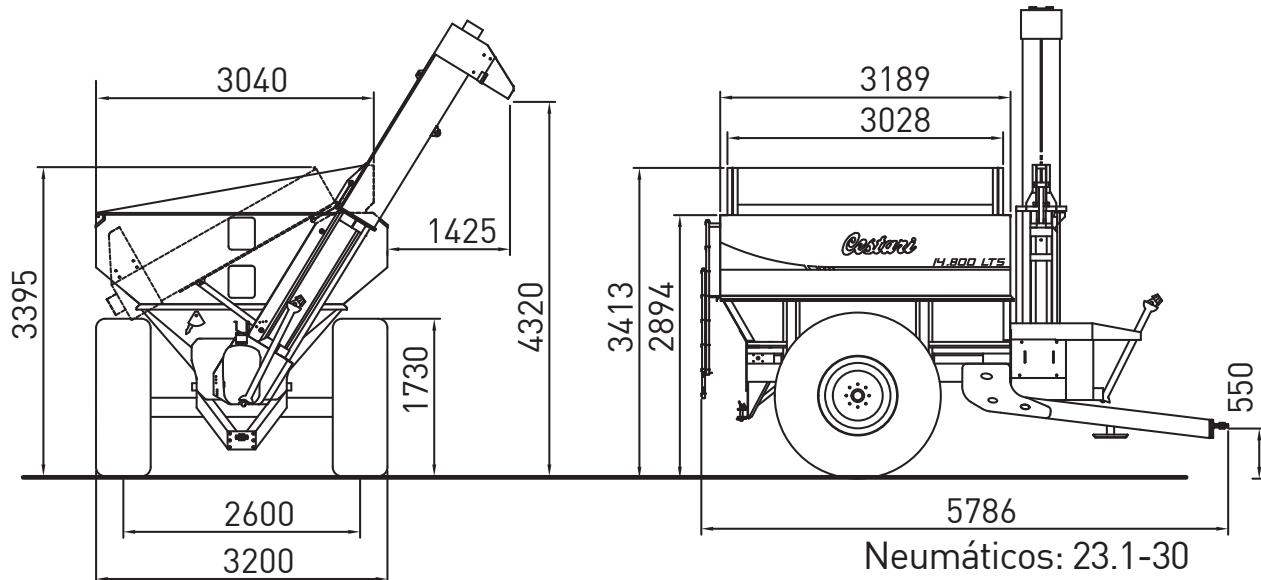

ST SERIES

ESPECIFICACIONES TÉCNICAS

Doble chasis / Estructura abulonada / Horquillas reforzadas (4R) / Masas de acero forjado / Puntas de eje: desmontables, templadas y bonificadas / Sistema de lanza fija / Sistema hidráulico de accionamiento del fondo deslizante (sistema de limpieza y descarga por gravedad) / Tubo inferior de descarga desmontable (tipo camisa).

EQUIPAMIENTO ESTÁNDAR

Escaleras normalizadas / Gato mecánico elevación (2R) / Indicador de apertura de compuertas de piso / Indicadores de ajuste del neumático / Llantas enteras: soldadas por fuera y dentro / Luces traseras fijas / Organizador de mangueras / Paragolpes trasero deslizante / Pintura poliuretánica / Sinfines con refuerzo doble espesor en los extremos y pernos desmontables abulonados.

OPCIONAL

Balanza / Cajón de herramientas / Gato hidráulico de elevación (2R) / Luces traseras rebatibles / Neumáticos a elección / Pintura base agua y epoxi fenólico / Sinfines con recargue duro en su totalidad o en sus extremos (cementados) / Sistema de cobertura con lona enrollable / Sistema de lubricación externa centralizada.

ST SERIES

TECHNICAL SPECIFICATIONS

Bolted structure / Bottom sliding floor driving by hydraulic system (cleaning system and gravity download) / Detachable and induction hardened spindles / Dual chassis / Forged hubs wheel / Reinforced Steering forks (4W) / Removable lower unloading tube (extension casing) / Welded towbar system (fixed).

STANDARD EQUIPMENT

Closed rims, welded inside and outside / Fixed rear lights / Floor hatches opening indicator / Hydraulic hoses organizer / Mechanical Lifting Jack (2W) / Polyurethane Painting / Reinforced augers with double thickness in the ends and detachable bolts / Sliding rear bumper / Standard Ladders: rear hinged and internal / Wheel adjustment indicators.

OPTIONAL

Centralised lubrication system / Hardfacing augers in whole or in its ends / Hinged rear lights / Hydraulic lifting Jack (2W) / Plastic Toolbox / Roll Top canvas system / Scale / Tyres / Water-based and epoxy phenolic painting.

ST SERIES



Más de 90 años liderando el sistema de cosecha.
More than 90 years leading the harvesting system.



 CestariTolvas  cestari tolvas  @CestariTolvas
 cestaritolvas  imcestari.com  00 54 2473 430490
 informes@imcestari.com

Av. Eva Perón 1068, Colón, Buenos Aires, Argentina



MANAGEMENT SYSTEM
ISO 9001:2015
ID 9105049530
WWW.TUV.COM



SEGURIDAD EN
MAQUINARIA AGRICOLA /
SAFETY IN AGRICULTURAL
MACHINERY
IRAM: 8076-0: 2011

XXI
SERIES



7000L



9000L



10000L

Cestari

XXISERIES

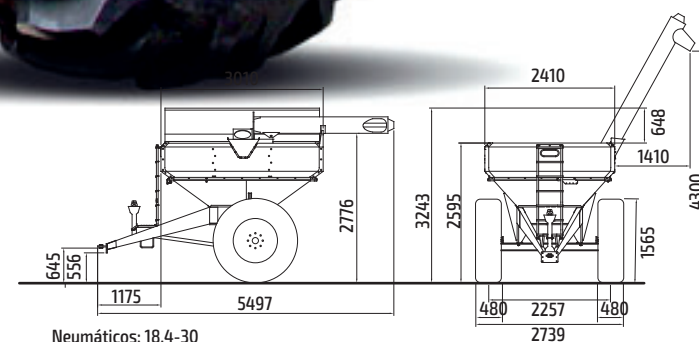

ESPECIFICACIONES TECNICAS TECHNICAL SPECIFICATIONS

7.000 L

Peso Tara	Weight Tare:	1.250 Kg (*1)
Capacidad	Capacity	7.000 Lts. (*2)
Carga máxima	Máximum load	6.000 Kg
Tiempo de descarga	Unloading time	3 min. (*3)
Ø tubo	Ø Tube	304 mm.
Ø sinfín de tubo	Ø Tube	280 mm.

EQUIPAMIENTO

Llantas: W 16x 30, W 16 x 34, DW 20x 26,
DW 20x30, DW 25 x 26, DW 21x 32
Neumáticos: 18.4-30, 18.4-34, 23.1-30, 28L-26, 24.5-32.

EQUIPMENT

Rims: W 16x 30, W 16 x 34, DW 20x 26,
DW 20x30, DW 25 x 26, DW 21x 32.
Tyres: 18.4-30, 18.4-34, 23.1-30, 28L-26, 24.5-32.

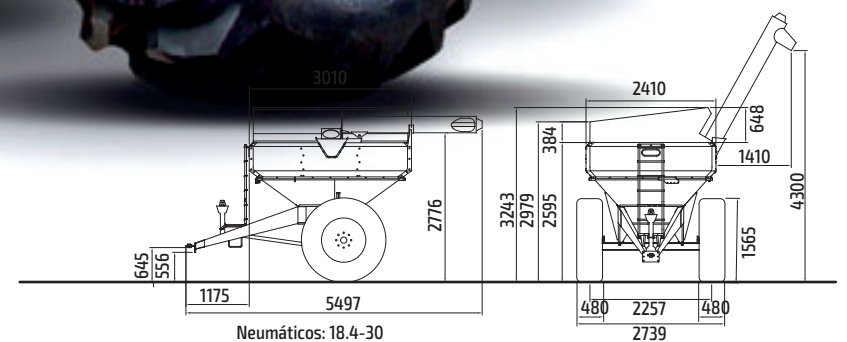

ESPECIFICACIONES TECNICAS
TECHNICAL SPECIFICATIONS

9.000 L

Peso Tara	Weight Tare:	1.400 Kg (*1)
Capacidad	Capacity	9.000 Lts. (*2)
Carga máxima	Máximum load	7.500 Kg
Tiempo de descarga	Unloading time	4 min. (*3)
Ø tubo	Ø Tube	304 mm.
Ø sinfín de tubo	Ø Tube	280 mm.

EQUIPAMIENTO

Llantas: W 16x 30, W 16 x 34, DW 20x 26,
DW 20x30, DW 25 x 26, DW 21x 32
Neumáticos: 18.4-30, 18.4-34, 23.1-30, 28L-26, 24.5-32.

EQUIPMENT

Rims: W 16x 30, W 16 x 34, DW 20x 26,
DW 20x30, DW 25 x 26, DW 21x 32.
Tyres: 18.4-30, 18.4-34, 23.1-30, 28L-26, 24.5-32.



ESPECIFICACIONES TECNICAS
TECHNICAL SPECIFICATIONS

Peso Tara	Weight Tare:	1.450 Kg (*1)
Capacidad	Capacity	10.000 Lts. (*2)
Carga máxima	Máximum load	8.000 Kg
Tiempo de descarga	Unloading time	4,3 min. (*3)
Ø tubo	Ø Tube	304 mm.
Ø sinfín de tubo	Ø Tube	280 mm.

10.000 L

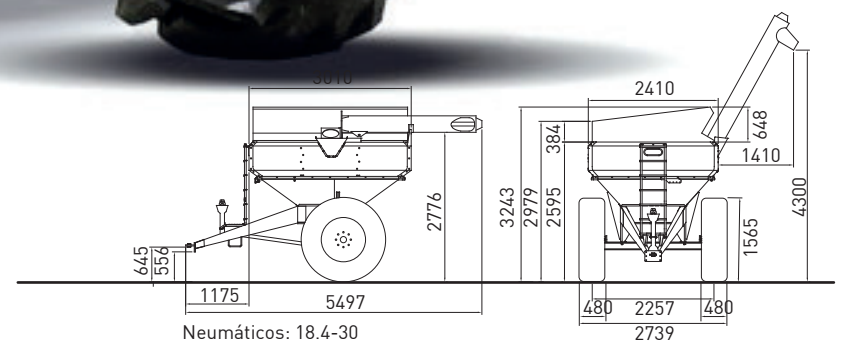

EQUIPAMIENTO

Llantas: W 16x 30, W 16 x 34, DW 20x 26,
DW 20x30, DW 25 x 26, DW 21x 32
Neumáticos: 18.4-30, 18.4-34, 23.1-30, 28L-26, 24.5-32.

EQUIPMENT

Rims: W 16x 30, W 16 x 34, DW 20x 26,
DW 20x30, DW 25 x 26, DW 21x 32.
Tyres: 18.4-30, 18.4-34, 23.1-30, 28L-26, 24.5-32.

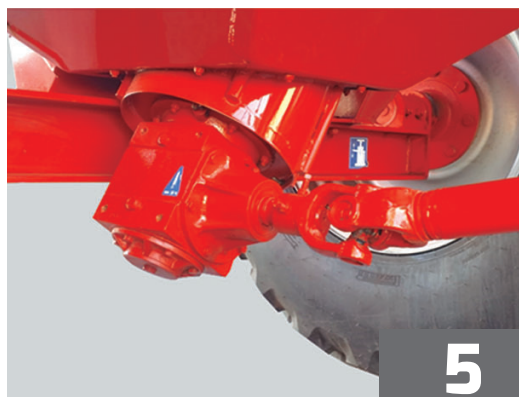
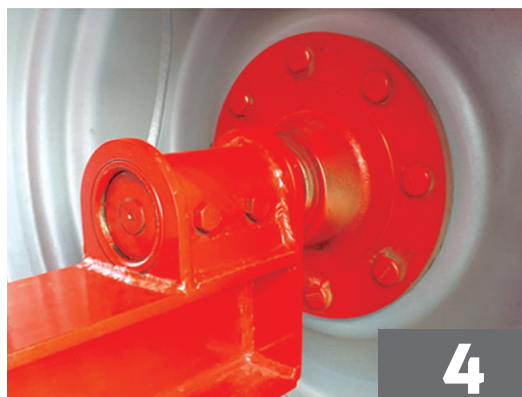
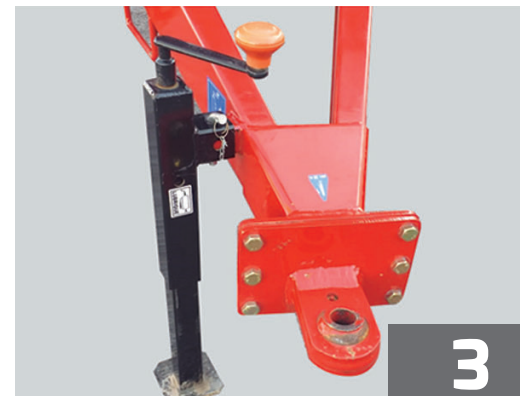

EQUIPAMIENTO EQUIPMENT

1. Bandeja recuperadora de cereal.
2. Escalera en el frente.
3. Enganche delantero abulonado con rótula y gato mecánico de elevación.
4. Eje con puntas de eje cambiables (abulonadas).
5. Caja transmisión de mandos con engranajes en baño de aceite.
6. Boquilla de descarga alternativa.

1. Cereal recovering tray.
2. Front ladder.
3. Bolted front hitch with keecap and mechanical lifting Jack.
4. Axle with interchangeable spindle (bolted splindles).
5. Gearbox with forged steel gears (in oil bath).
6. Alternative unloading nozzle.

OPCIONALES

Balanza.
Lona enrollable.
Compuerta hidráulica en tubo inferior para entrada de cereal.

RECOMENDACIÓN

Terrenos normales: Tractor de 40 a 60 HP.
Terrenos blandos: Tractor de 60 a 80 HP.

OPTIONAL

Scale.
Roll top canvas system.
Hydraulic gate located in the lower tube for the cereal input.

RECOMMENDATION

Regular ground: 40 to 60 HP tractor.
Soft ground: 40 to 60 HP tractor.

www.imcestari.com



CestariTolvas

INDUSTRIAS METALÚRGICAS CESTARI S.R.L.

+54 2473 430490 / informes@imcestari.com / Colón Buenos Aires, Argentina